

Piece by Piece Quilters January 2009 Block of the Month

# Canned Food Jars

Cut jar fabric 5 1/2" x 9" Use fabric that looks like food, Such as strawberries, peas, nuts, apples, etc...anything you like ~~to~~ *PLEASE USE YOUR SCRAPS*

Cut Lid from supplied fabric 4" x 1 1/4"

Cut Background from white fabric:

- 2 squares @ 1 1/2" square
- 4 squares @ 1 1/4" square

Sew two 1 1/2" squares to top corners of jar fabric. Place right sides together and match outside corners. Sew on diagonal lines as shown below. Press the background fabric towards the outside of the jar fabric.

Sew two 1 1/4" squares at bottom corners using the same method.

Sew a 1 1/4" square to each side of the lid.

Sew this piece to the top of the jar and you are done canning for this season!

If you have any questions, ~~please call Nancy Redmond at home: 408-683-1190 or cell: 408-658-9900~~

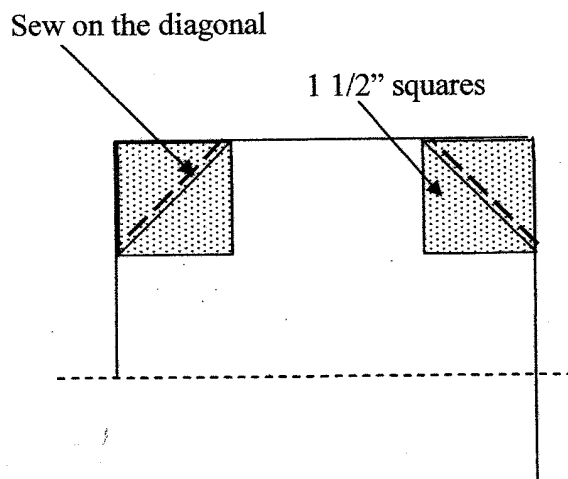
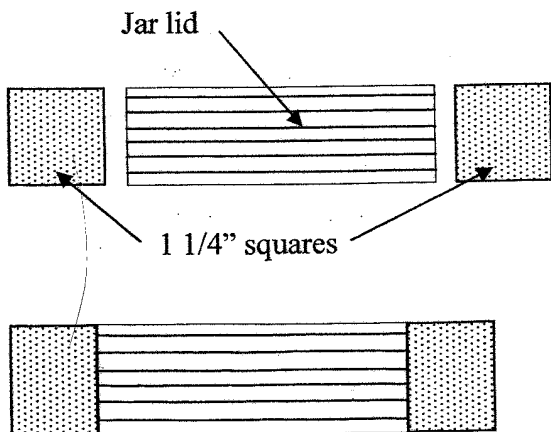
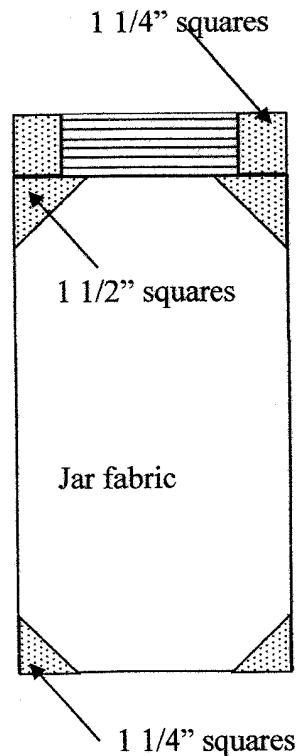

QUESTIONS? 408-422-9103  
Evelyn M. Sullivan

*PLEASE USE YOUR SCRAPS!!*